

INSTALLATION INSTRUCTION
TOYOTA LC 250NS Roof Platform

丰田LC 250
TOYOTA LC 250

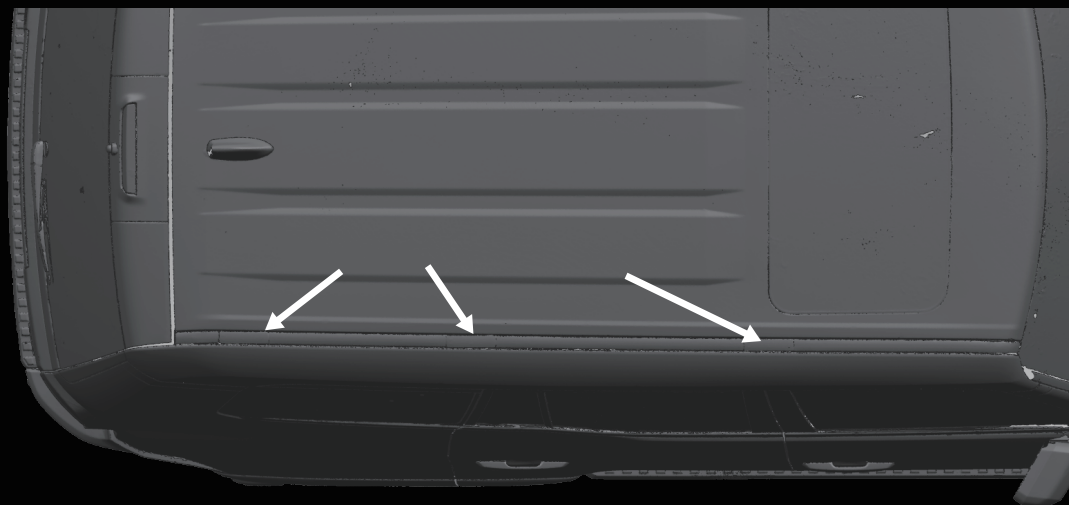

01.



拆除原车行李架安装位盖板和盖板下螺丝
REMOVE THE ORIGINAL LUGGAGE RACK MOUNTING COVER AND THE SCREWS UNDER THE COVER

02.

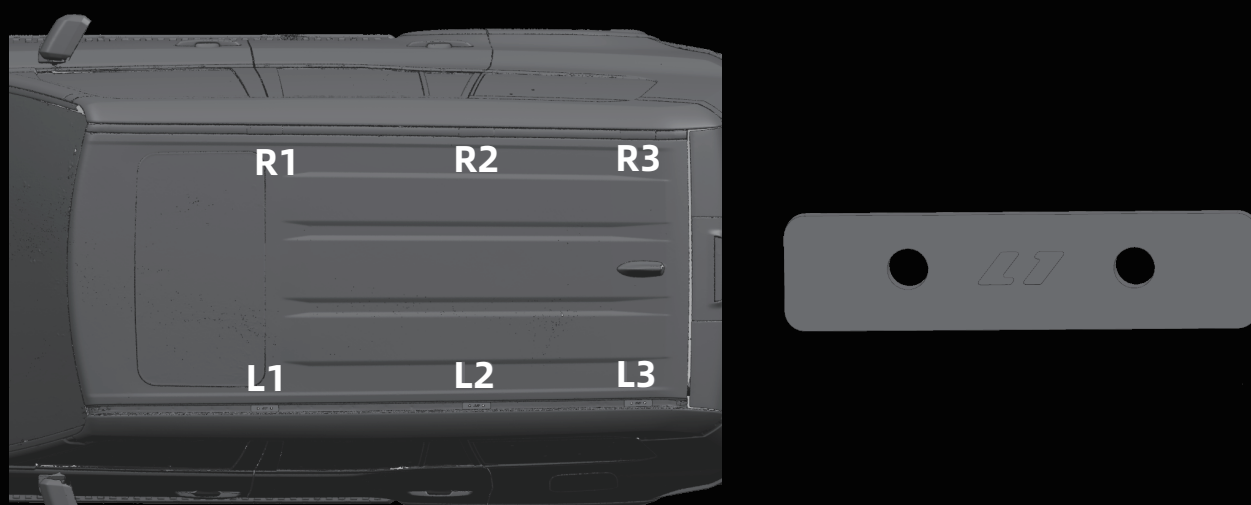

在安装螺丝孔周围打密封胶并放入对应垫块（注意：垫款上字体向外）
APPLY SEALANT AROUND THE MOUNTING SCREW HOLES AND PUT IN THE CORRESPONDING PADS (NOTE: THE FONT ON THE PADS FACES OUTWARD)

03.

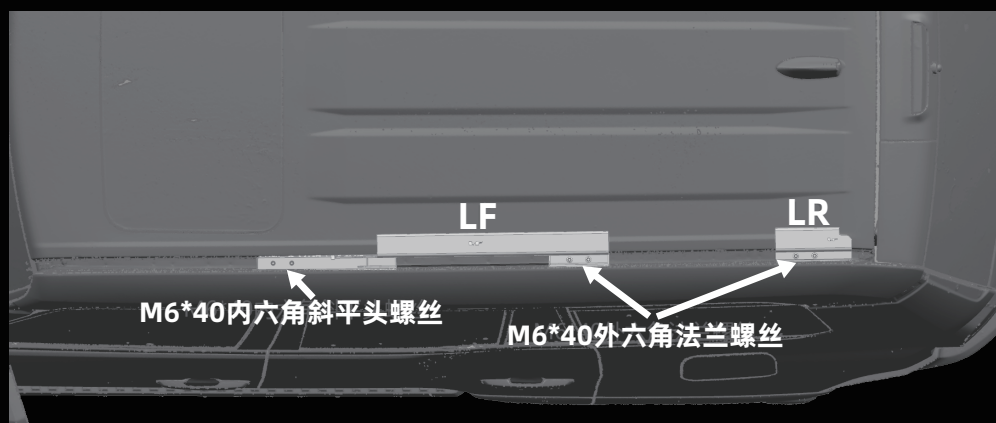

按照对应的支架标号进行安装支架并使用螺丝固定
(注意：车前位置使用斜平头M8*40螺丝，中间与后面使用为六角M8*40法兰螺丝，
螺丝先不需要锁紧，固定后可以移动即可)

INSTALL THE BRACKET ACCORDING TO THE CORRESPONDING BRACKET NUMBER AND FIX IT WITH SCREWS
(NOTE: USE THE OBLIQUE FLAT HEAD M8*40 SCREWS IN THE FRONT POSITION OF THE CAR, AND USE THE HEXAGONAL M8*40
FLANGE SCREWS IN THE MIDDLE AND THE BACK. THE SCREWS DO NOT NEED TO BE TIGHTENED FIRST, AND CAN BE MOVED AFTER FIXING)

04.



组装扰流板与扰流板支架

(注意：中间使用对应的马车螺栓与垫片方头螺母固定，两侧使用M6斜平头螺丝固定)

ASSEMBLE THE SPOILER AND SPOILER BRACKET (NOTE: USE THE CORRESPONDING CARRIAGE SCREWS AND GASKET SQUARE HEAD NUTS TO FIX IN THE MIDDLE, AND USE M6 OBLIQUE FLAT HEAD SCREWS TO FIX ON BOTH SIDES)

05.

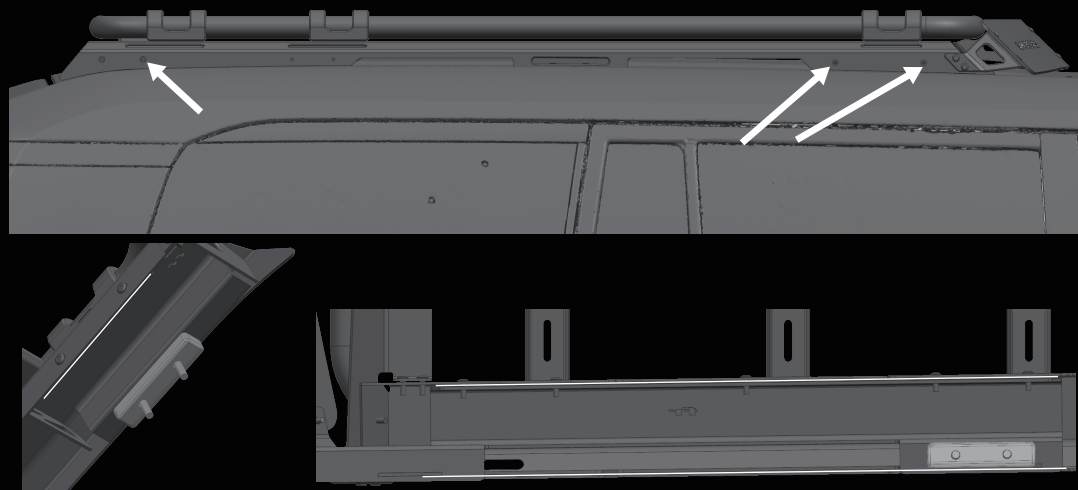

将行李架放在车顶上，进行调整两颗支架，并锁紧安装支架螺丝
(注意：行李架必须卡在支架内)

PUT THE LUGGAGE RACK ON THE ROOF, ADJUST THE TWO BRACKETS, AND TIGHTEN THE MOUNTING BRACKET SCREWS
(NOTE: THE LUGGAGE RACK MUST BE STUCK IN THE BRACKET)

06.

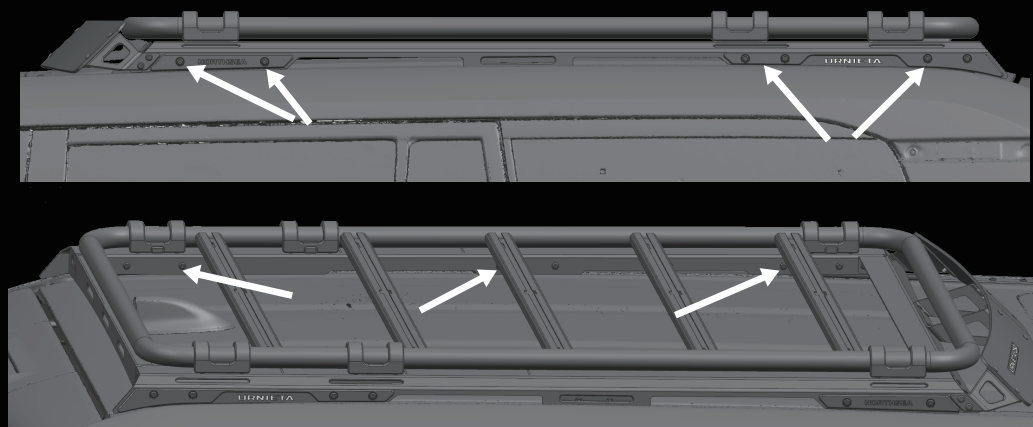

锁紧安装支架螺丝，对准螺丝孔后安装LOGO及行李架与支架螺丝

(注意：使用内六角斜平头螺丝M6*14)

TIGHTEN THE MOUNTING BRACKET SCREWS, ALIGN THE SCREW HOLES AND INSTALL THE LOGO AND THE LUGGAGE RACK AND BRACKET SCREWS
(NOTE: USE THE HEXAGONAL OBLIQUE FLAT HEAD SCREWS M6*14)

产品参数

PRODUCT PARAMETERS

NAME	产品名称	LC250NS车顶拓展平台
MATERIAL	材质	铝镁合金/复合树脂
COLOUR	颜色	武士黑
SPECIFICATIONS	产品规格	1806MM*1188MM*118MM

出厂配置

FACTORY CONFIGURATION

名称	平台总车	安装底座
	扰流板	拓展带