

URNIETA®

ROOF
CONSOLE

集成机顶盒
安装说明书

适用范围：LC78--2024款
APPLICABLE SCOPE: LC78-2024

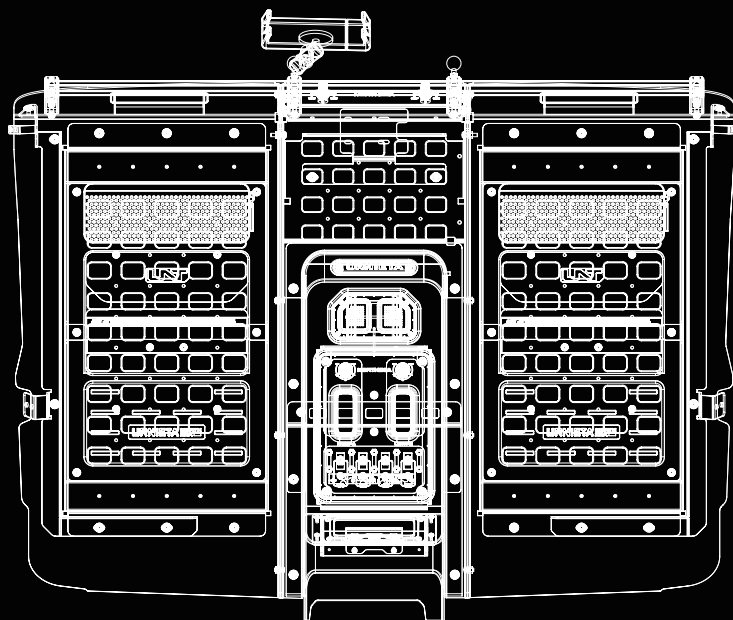

01.

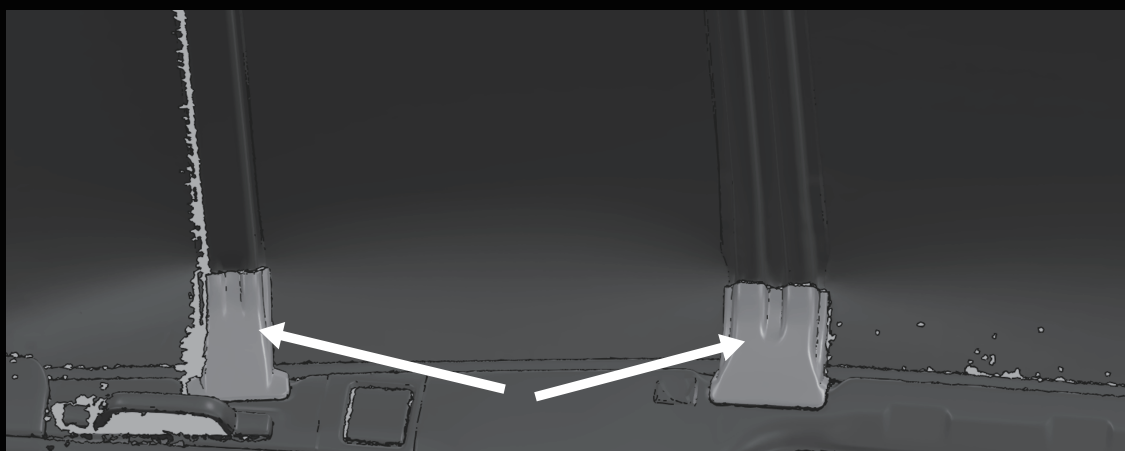

拆除原车前部第一与第二车顶横梁装饰盖板

REMOVE THE FIRST AND SECOND ROOF BEAM DECORATIVE COVERS FROM THE ORIGINAL FRONT OF THE VEHICLE

02.

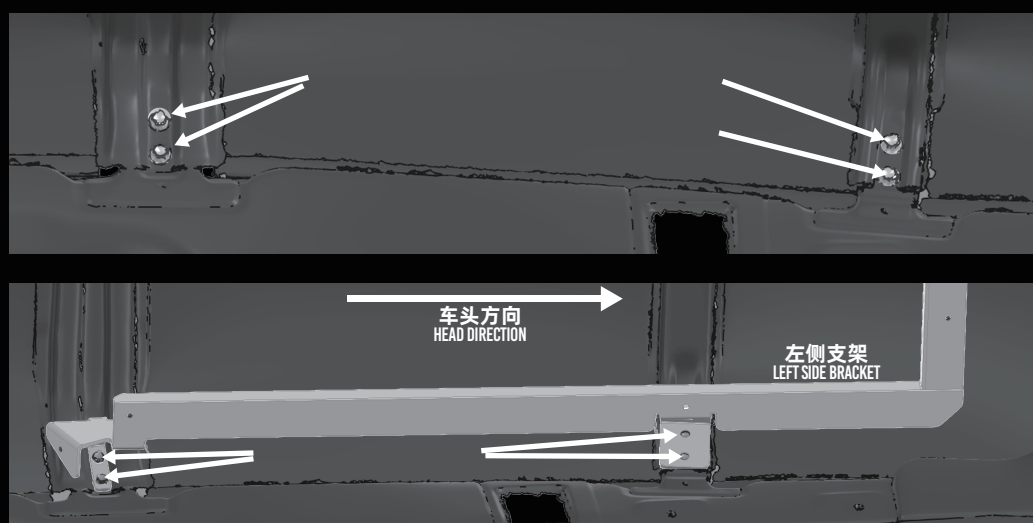

拆除左右两侧横梁螺丝，安装机顶盒专用支架并使用原车螺丝固定

REMOVE THE SCREWS ON THE LEFT AND RIGHT SIDES OF THE CROSSBAR, INSTALL THE SET-TOPTOP BOX BRACKET AND FIX IT WITH THE ORIGINAL CAR SCREWS

03.

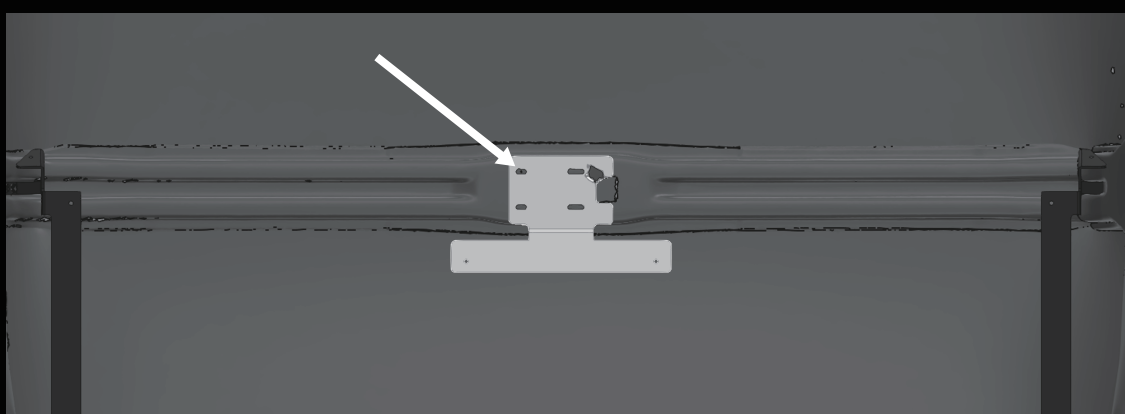

拆除中间照明灯并使用原车螺丝固定新支架

REMOVE THE CENTER LIGHT AND SECURE THE NEW BRACKET WITH THE ORIGINAL SCREWS

04.

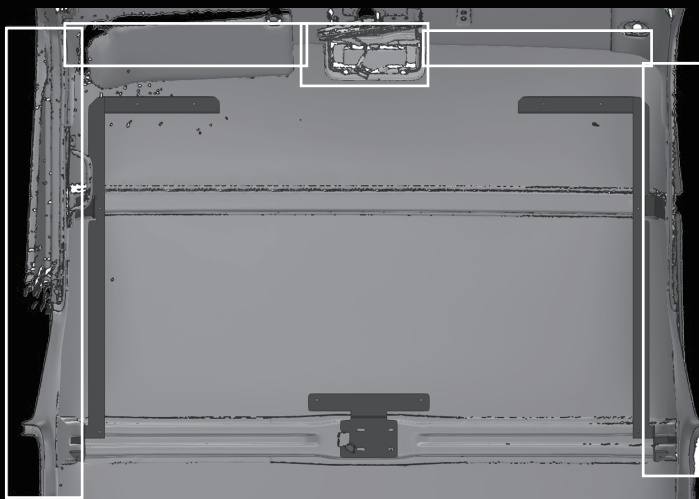

使用美容纸粘住安装位置以便于机顶盒安装不蹭到原车漆面

USE BEAUTY PAPER TO STICK TO THE INSTALLATION LOCATION TO FACILITATE THE INSTALLATION OF THE SET-TOP BOX WITHOUT SCRATCHING THE ORIGINAL CAR PAINT SURFACE

05.

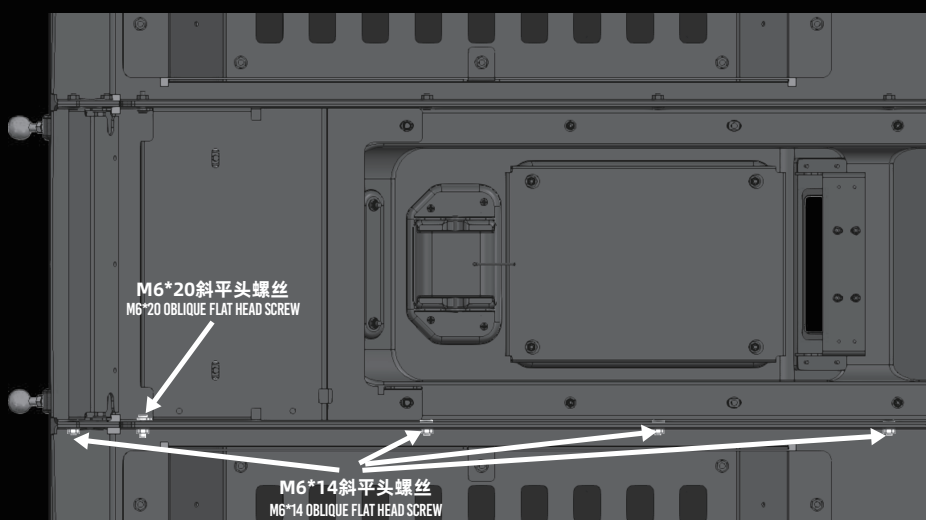

使用组装螺丝组装机顶盒

ASSEMBLING THE SET-TOP BOX USING ASSEMBLY SCREWS

06.

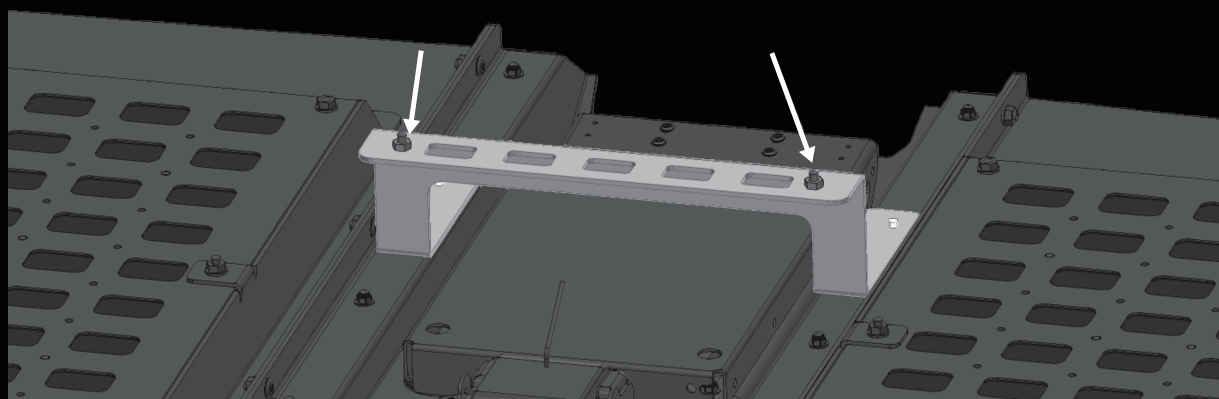

将中间支架安装在机顶盒上，并使用定位吉米安装在标记孔位

INSTALL THE MIDDLE BRACKET ON THE SET-TOP BOX AND USE THE POSITIONING JIMI TO INSTALL IT IN THE MARKED HOLE POSITION

07.

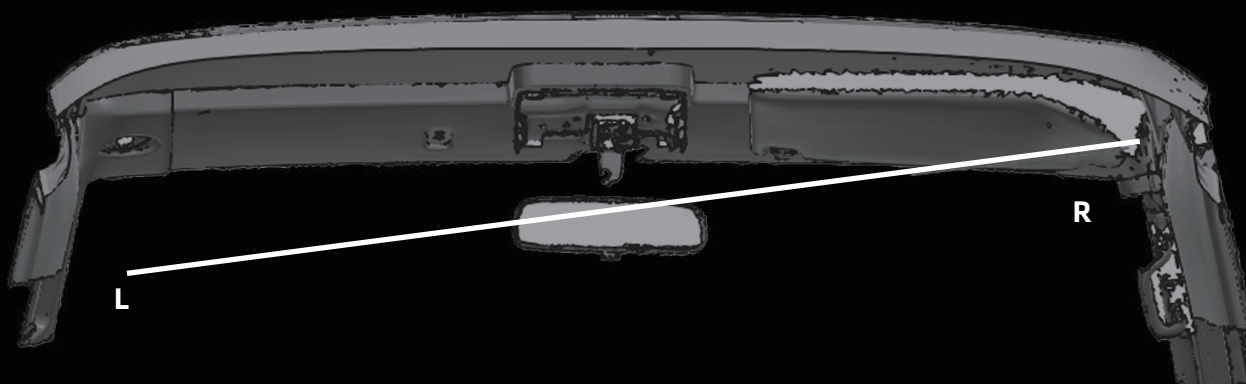

使用安装螺丝将机顶盒整体预安装在车上（注意：装车时斜着先放入一侧再将另外一侧推上去）

USE THE MOUNTING SCREWS TO PRE-INSTALL THE SET-TOP BOX ON THE VEHICLE (NOTE: WHEN LOADING THE VEHICLE, PUT ONE SIDE IN FIRST AND THEN PUSH THE OTHER SIDE UP)

08.



使用螺丝将机顶盒固定在车顶上
USE SCREWS TO FIX THE SET-TOP BOX ON THE ROOF

09.

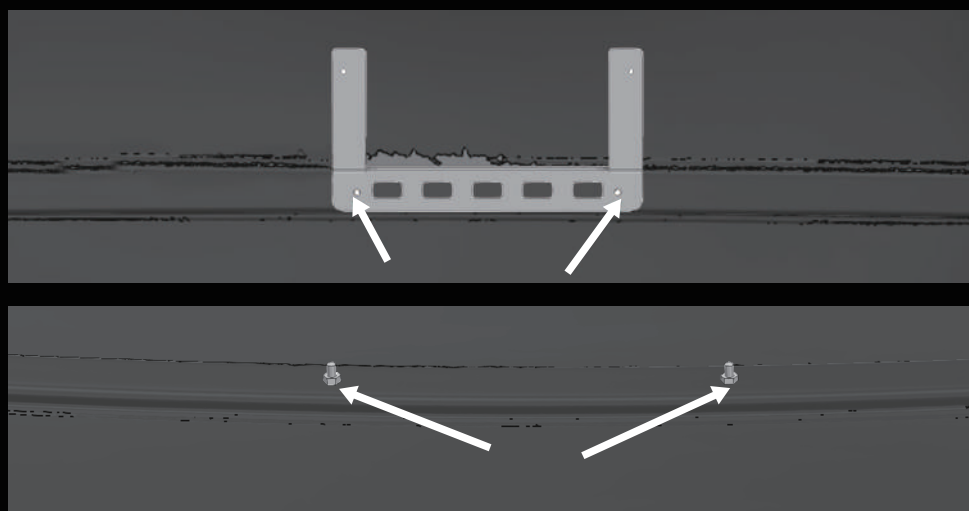

安装好之后捶打中间位置，使既定定位吉米在原车第一根横梁留下标记
AFTER INSTALLATION, HAMMER THE MIDDLE POSITION TO MARK THE FIRST CROSSBEAM OF THE ORIGINAL CAR.

10.

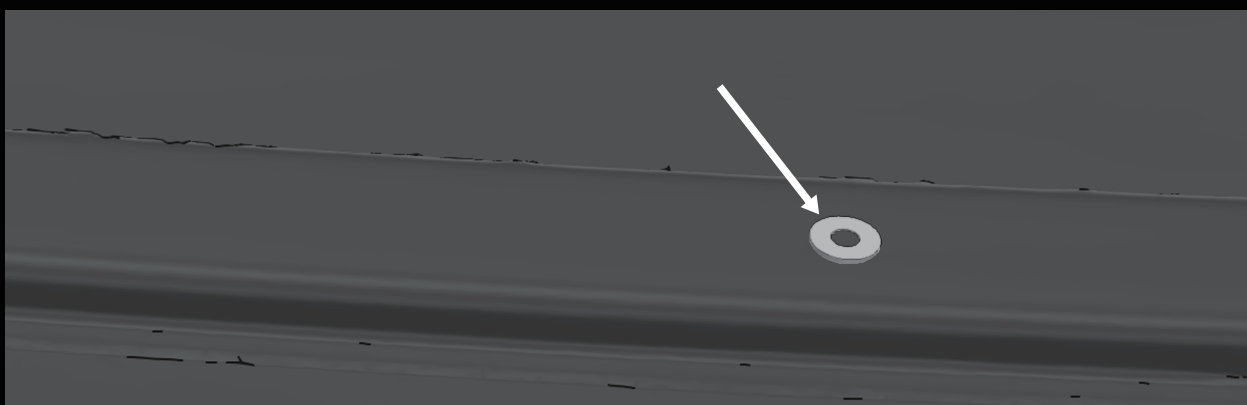

拆下机顶盒并取下支架及定位吉米，并在标记位置使用8.9MM钻头打孔，使用拉铆枪拉M6铆接螺丝
REMOVE THE SET-TOP BOX, REMOVE THE BRACKET AND POSITION JIMI, AND USE AN 8.9MM DRILL TO DRILL HOLES AT THE MARKED POSITIONS, AND USE A RIVET GUN TO PULL THE M6 RIVET SCREWS.

11.

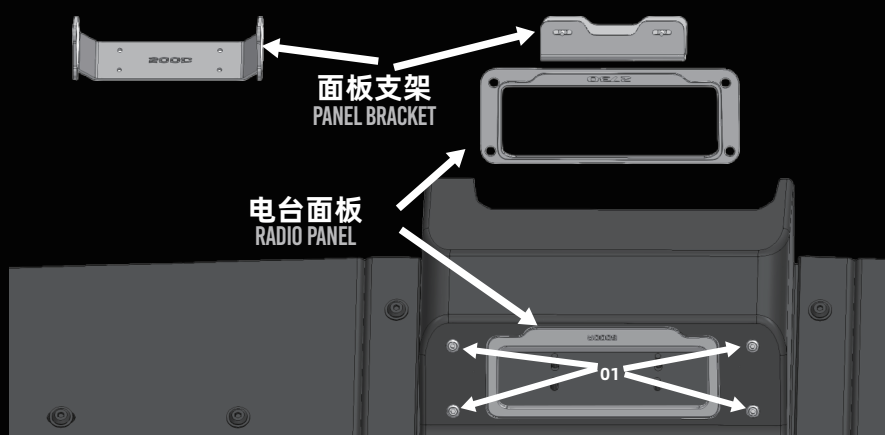

将选装好的电台安装在机顶盒位置（注意：标配安装的是2730E支架，如果是6000R电台需要更换电台面板及面板支架，500D支架拆除电台面板外框）
INSTALL THE SELECTED RADIO IN THE SET-TOP BOX POSITION (NOTE: THE STANDARD INSTALLATION IS 2730E BRACKET. IF IT IS 6000R RADIO, THE RADIO PANEL AND PANEL BRACKET NEED TO BE REPLACED. FOR 500D BRACKET, THE RADIO PANEL FRAME NEEDS TO BE REMOVED.)

12. 接线方式1: WIRING METHOD 1:

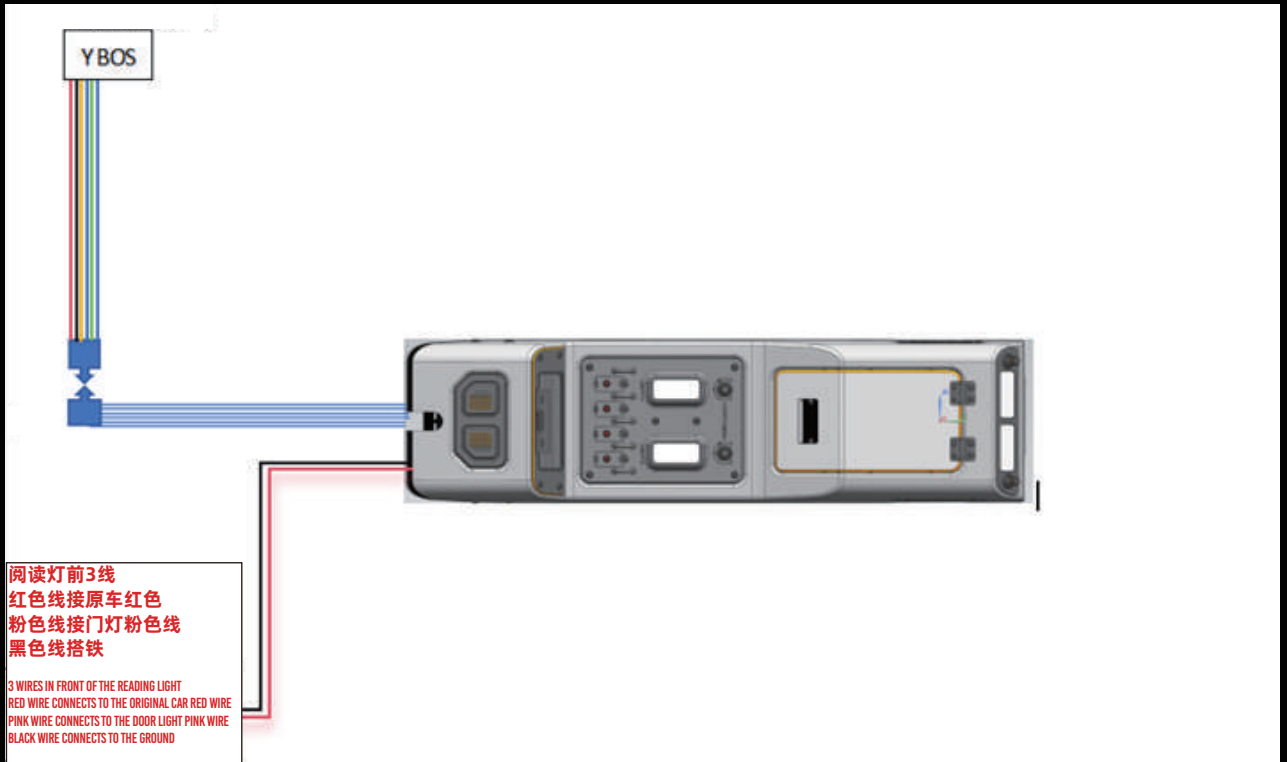

接线方式2: WIRING METHOD 2:

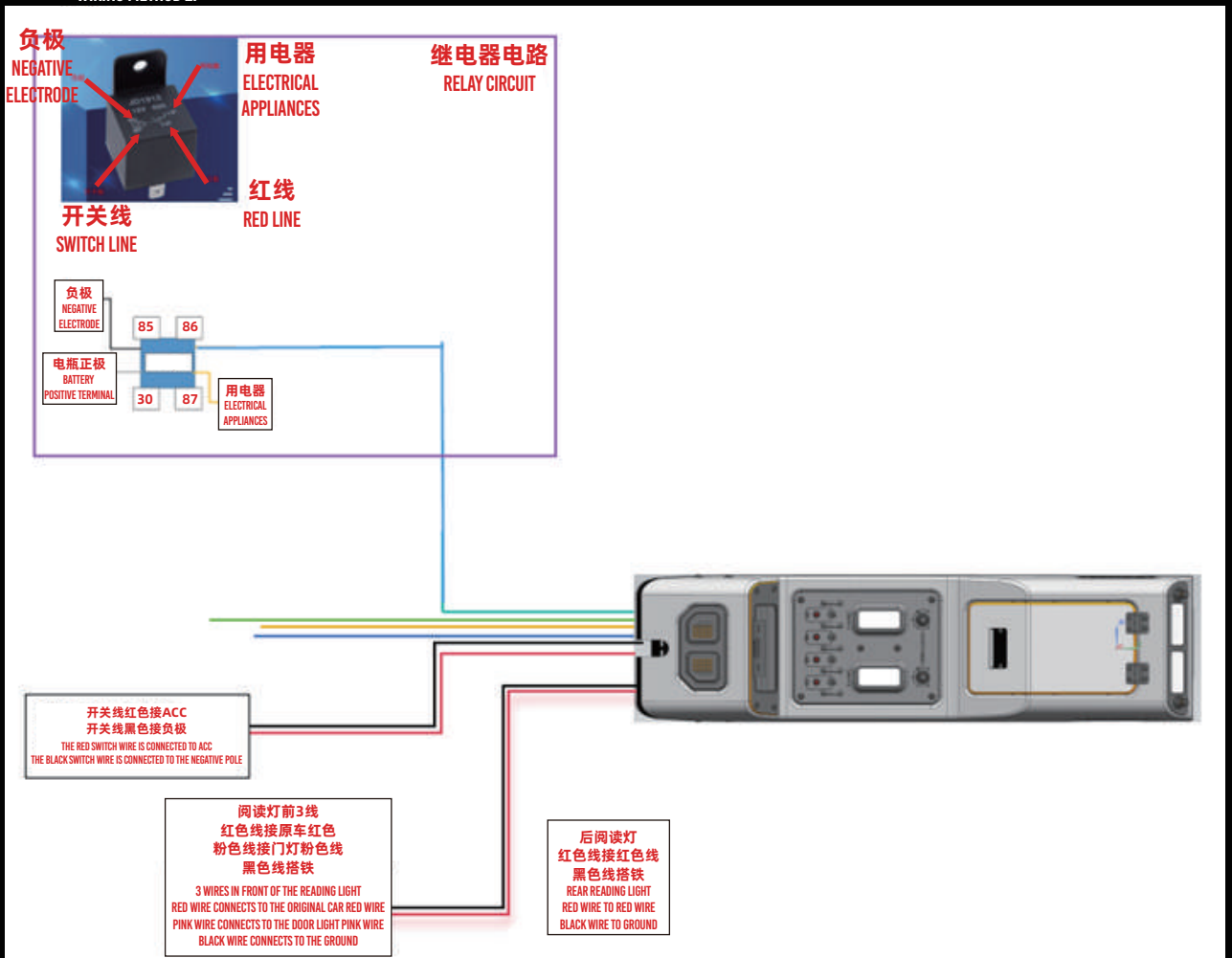

将照明灯线束破线接在原车位置上（建议前面灯接在开门亮，后面接旋钮亮）

CONNECT THE BROKEN WIRES OF THE LIGHTING HARNESS TO THE ORIGINAL POSITION OF THE CAR
(IT IS RECOMMENDED THAT THE FRONT LIGHTS BE CONNECTED TO THE DOOR OPENING LIGHT AND THE REAR LIGHTS BE CONNECTED TO THE KNOB LIGHT)

13.

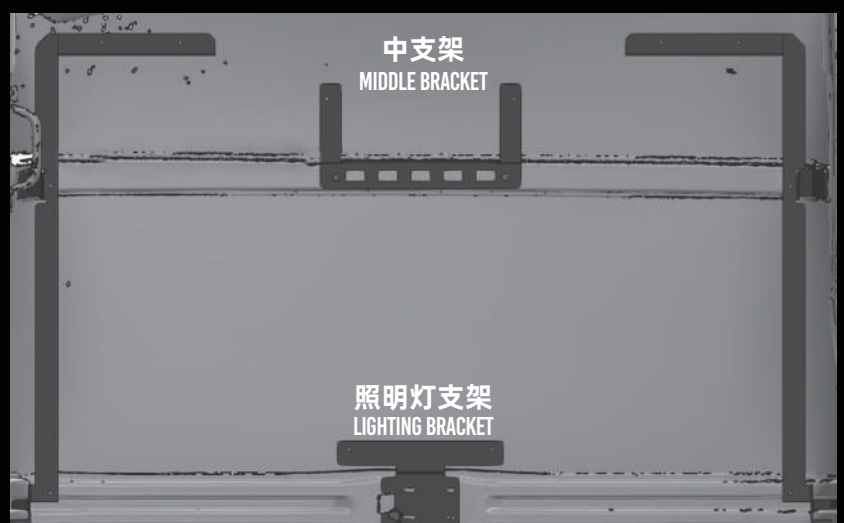

使用原车螺丝安装照明灯支架，使用中支架螺丝安装中支架

USE THE ORIGINAL CAR SCREWS TO INSTALL THE LIGHTING BRACKET, AND USE THE MIDDLE BRACKET SCREWS TO INSTALL THE MIDDLE BRACKET

14.



安装组装好电台的机顶盒，并留好线束位置以便于插线束

INSTALL THE ASSEMBLED RADIO SET-TOP BOX AND LEAVE THE WIRING HARNESS POSITION FOR EASY INSERTION

使用安装螺丝安装机顶盒

INSTALL THE SET-TOP BOX USING THE MOUNTING SCREWS

■ 产品参数

PRODUCT PARAMETERS

NAME	产品名称	LC78NS集成机顶盒
COLOUR	颜色	武士黑
SPECIFICATIONS	产品规格	1301*971*212MM